



**SINGLE-PHASE BRIDGE RECTIFIER**

DB101 THRU DB107  
DF005 THRU DF10

**VOLTAGE RANGE**  
**CURRENT**

**50 to 1000 Volts**  
**1.0 Ampere**

**FEATURES**

- Glass passivated chip junction.
- High forward surgecurrent capability
- Ideal for printed circuit board
- High temperature soldering guaranteed:  
260°C/10 seconds at 5 lbs. (2.3kg) tension

**MECHANICAL DATA**

- Case: Transfer molded plastic
- Epoxy: UL94V - 0 rate flame retardant.
- Terminal: Lead solderable per MIL - STD - 202E method 208C
- Polarity: Molded on body
- Mounting position : Any
- Weight: 0.04 ounce, 1.0 gram

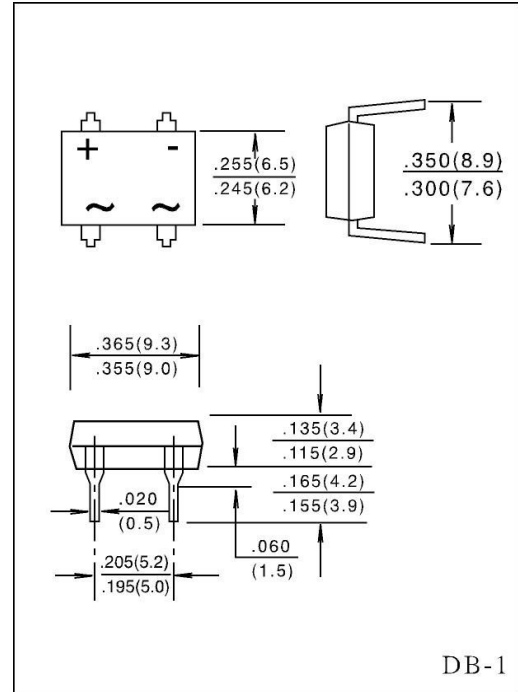

**MAXIMUM RATINGS AND ELECTRICAL CHARACTERISTICS**

- Ratings at 25°C ambient temperature unless otherwise specified
- Single phase, half wave, 60Hz, resistive or inductive load.
- For capacitive load derate current by 20%

	SYMBOLS	DF005	DF01	DF02	DF04	DF06	DF08	DF10	UNIT
		DB101	DDB102	DB103	D104	DB105	DB106	DB107	
Maximum Repetitive Peak Reverse Voltage	$V_{RRM}$	50	100	200	400	600	800	1000	Volts
Maximum RMS Voltage	$V_{RMS}$	35	70	140	280	420	560	700	Volts
Maximum DC Blocking Voltage	$V_{DC}$	50	100	200	400	600	800	1000	Volts
Maximum Average Forward Rectified Output Current, 0.06" (0.5mm) lead length at $T_A = 40^\circ C$ (Note)	$I_{(AV)}$	1.0							Amp
Peak Forward Surge Current 8.3ms single half sine - wave superimposed on rated load (JEDEC method )	$I_{FSM}$	50							Amps
Rating for Fusing (t<8.3ms)	$I^2t$	10							$A^2s$
Maximum Instantaneous Forward Voltage Drop per bridge element at 1.0A	$V_F$	1.10							Volts
Maximum DC Reverse Current at rated DC blocking voltage per element	$I_R$	$T_A = 25^\circ C$							$\mu A$
		$T_A = 125^\circ C$							mA
Typical Junction Capacitance (Note 1 )	$C_j$	25							pF
Typical Thermal Resistance (Note 2)	$R_{\theta JA}$	40							$^\circ C/W$
Operating and Storage Temperature Range	$T_J, T_{STG}$	(-65 to +150)							$^\circ C$

**NOTES:**

1. Measured at 1.0 MHz and applied reverse voltage of 4.0 Volts.
2. Unit mounted on P.C.B.with 0.51" X 0.51" (13 X13 mm) copper pads

FIG.1-DERATING CURVE FOR  
OUTPUT RECTIFIED CURRENT

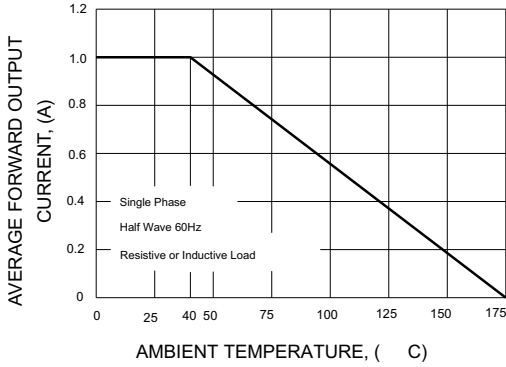

FIG.2-MAXIMUM NON-REPETITIVE PEAK  
FORWARD SURGE CURRENT PER ELEMENT

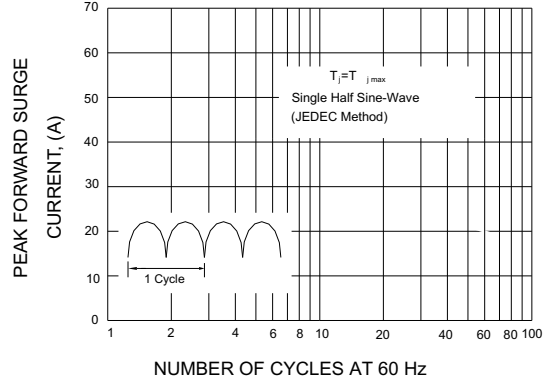

FIG.3-TYPICAL FORWARD CHARACTERISTICS  
PER BRIDGE ELEMENT

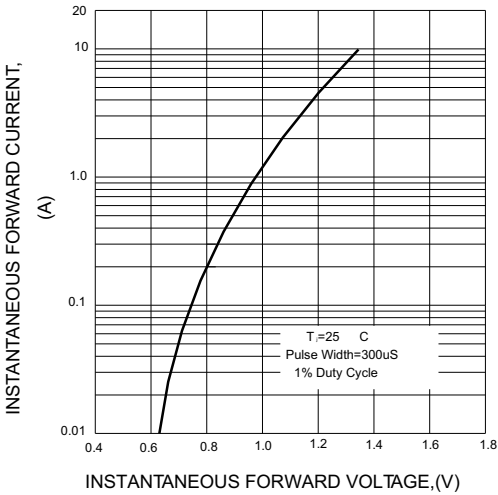

FIG.4-TYPICAL REVERSE CHARACTERISTICS  
PER BRIDGE ELEMENT

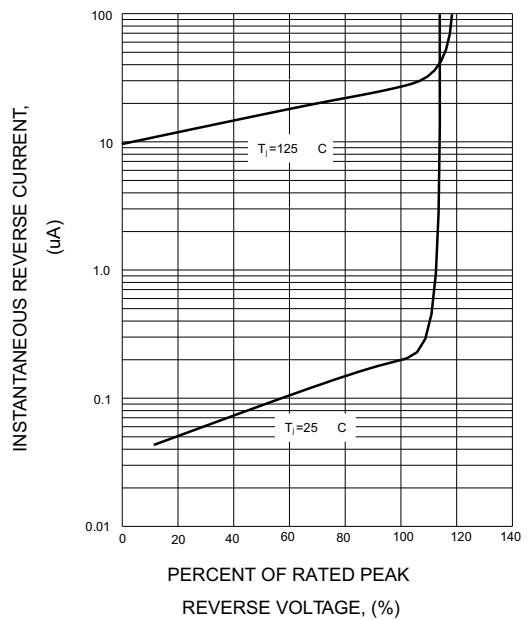

FIG.5-TYPICAL JUNCTION CAPACITANCE  
PER BRIDGE ELEMENT

